

ICC-ES Evaluation Report

ESR-3699

Reissued March 2024

This report also contains:

Subject to renewal March 2026

- LABC Supplement
- CBC Supplement
- FBC Supplement

ICC-ES Evaluation Reports are not to be construed as representing aesthetics or any other attributes not specifically addressed, nor are they to be construed as an endorsement of the subject of the report or a recommendation for its use. There is no warranty by ICC Evaluation Service, LLC, express or implied, as to any finding or other matter in this report, or as to any product covered by the report.

Copyright © 2024 ICC Evaluation Service, LLC. All rights reserved.

<p>DIVISION: 03 00 00— CONCRETE</p> <p>Section: 03 16 00— Concrete Anchors</p> <p>DIVISION: 05 00 00— METALS</p> <p>Section: 05 05 19—Post- Installed Concrete Anchors</p>	<p>REPORT HOLDER: ITW RED HEAD</p> <p>ADDITIONAL LISTEE: ITW BRANDS</p>	<p>EVALUATION SUBJECT: TAPCON+ SCREW ANCHORS AND SAMMYS THREADED ROD ANCHORS FOR USE IN CRACKED AND UNCRACKED CONCRETE</p>	
--	---	---	---

1.0 EVALUATION SCOPE

Compliance with the following codes:

- 2021, 2018, 2015, and 2012 [International Building Code® \(IBC\)](#)
- 2021, 2018, 2015, and 2012 [International Residential Code® \(IRC\)](#)

For evaluation for compliance with codes adopted by [Los Angeles Department of Building and Safety \(LADBS\)](#), see [ESR-3699 LABC and LARC Supplement](#).

Property evaluated:

- Structural

2.0 USES

The 1/4-inch-, 3/8-inch-, and 1/2-inch-diameter (6.4 mm, 9.5 mm, and 12.7 mm) Tapcon+ Screw Anchors with Advanced Threadform Technology are used as anchorage in cracked and uncracked normalweight and lightweight concrete having a specified compressive strength $f'_c = 2,500$ psi to 8,500 psi (17.2 MPa to 58.6 MPa) to resist static, wind, and seismic tension and shear loads.

The 1/2-inch-diameter (12.7 mm) Tapcon+ Screw Anchors with Advanced Threadform Technology are also used as anchorage when installed in the soffit of cracked and uncracked normalweight and sand-lightweight concrete over steel deck having a minimum specified compressive strength $f'_c = 3,000$ psi (20.7 MPa) to resist static, wind, and seismic tension and shear loads.

The 1/4-inch-diameter (6.4 mm) SAMMYS Anchors for use with threaded rods are available in two head styles: the SAMMYS vertical threaded rod anchor, CCST 516; and SAMMYS horizontal threaded rod anchor, SW-CCST 516. The CCST 516 anchor is used as anchorage in cracked and uncracked normalweight and sand-lightweight concrete having a specified compressive strength $f'_c = 2,500$ psi to 8,500 psi (17.2 MPa to 58.6 MPa) to resist static and wind, tension or shear loads, and seismic tension loads only. The SW-CCST 516 anchor is used as anchorage in uncracked normalweight and sand-lightweight concrete having a specified compressive strength $f'_c = 2,500$ psi to 8,500 psi (17.2 MPa to 58.6 MPa) to resist static and wind shear loads only.

The anchoring system is an alternative to cast-in-place anchors described in Section 1901.3 of the 2021, 2018 and 2015 IBC, and Sections 1908 and 1909 of the 2012 IBC. The anchors may also be used where an engineered design is submitted in accordance with Section R301.1.3 of the IRC.

3.0 DESCRIPTION

3.1 Tapcon+ Anchors with Advanced Threadform Technology:

The Tapcon+ Anchors with Advanced Threadform Technology are manufactured from carbon steel with supplementary heat treatment. The anchors have an alternating high-low thread form on the shank and are available a variety of lengths with nominal diameters of $\frac{1}{4}$ -inch, $\frac{3}{8}$ -inch, and $\frac{1}{2}$ -inch (6.4 mm, 9.5 mm, and 12.7 mm). The Tapcon+ Screw Anchors are available with a hex washer head, and have a blue Climaseal® coating. Illustrations of anchors are provided in [Figure 1](#).

3.2 SAMMYS Anchors for Threaded Rods:

The SAMMYS Screw Anchor is a two-piece, carbon steel threaded anchor that is comprised of the $\frac{1}{4}$ -inch-diameter (6.4 mm) Tapcon+ Screw Anchor with Advanced Threadform Technology and a $\frac{3}{8}$ -inch-16 UNC internal thread hex shaped cap. The hex shaped cap is manufactured from carbon steel alloy complying with UNS G1010 heat treated steel and has an electrodeposited coating of zinc, minimum thickness of 0.0002 inch (5 μ m), in accordance with ASTM B633, SC1, Type III.

The SAMMYS Screw Anchors are available with a $2\frac{1}{2}$ -inch (63.5 mm) length. Two models are available: SAMMYS Vertical Threaded Rod Anchor (Model No. CCST 516) and SAMMYS Horizontal Threaded Rod Anchor (Model No. SW-CCST 516). [Figure 3](#) illustrates the SAMMYS vertical threaded rod anchor and SAMMYS horizontal threaded rod anchor with their torque limiting installation tools. The installation tools are designed to prevent over torque conditions upon installation. The design also permits the nut driver to release from the head of the anchor once fully installed.

3.3 Concrete:

Normalweight and lightweight concrete must comply with Sections 1903 and 1905 of the IBC, as applicable.

3.4 Steel Deck Panels:

Steel deck panels must comply with the configurations in [Figure 6](#) and have a minimum base steel thickness of 0.034 inch (0.864 mm). Steel must comply with ASTM A653 Grade 40, with a minimum yield strength of 40,000 psi (276 MPa).

4.0 DESIGN AND INSTALLATION

4.1 Strength Design:

4.1.1 General: Design strength of anchors complying with the 2021 IBC, as well as Section R301.1.3 of the 2021 IRC must be determined in accordance with ACI 318-19 Chapter 17 and this report

Design strength of anchors complying with the 2018 and 2015 IBC, as well as Section R301.1.3 of the 2018 and 2015 IRC must be determined in accordance with ACI 318-14 Chapter 17 and this report.

Design strength of anchors complying with the 2012 IBC and Section R301.1.3 of the 2012 IRC, must be determined in accordance with ACI 318-11 Appendix D and this report.

Design parameters provided in [Tables 1, 2, 3](#) and [5](#) are based on the 2021 IBC (ACI 318-19), 2018 and 2015 IBC (ACI 318-14) and 2012 IBC (ACI 318-11) unless noted otherwise in Sections 4.1.2 through 4.1.12 of this report.

The strength design must comply with ACI 318-19 17.5.1.2, ACI 318-14 17.3.1 or ACI 318-11 D.4.1, except as required in ACI 318-19 17.10, ACI 318-14 17.2.3 or ACI 318-11 D.3.3, as applicable. Strength reduction factors, ϕ , as given in ACI 318-19 17.5.3, ACI 318-14 17.3.3 or ACI 318-11 Section D.4.3, as applicable, and noted in [Tables 2, 3](#), and [5](#) must be used for load combinations calculated in accordance with Section 1605.1 of the 2021 IBC or Section 1605.2 of the 2018, 2015 and 2012 IBC, Section 5.3 of ACI 318 (-19 and -14) or Section 9.2 of ACI 318-11, as applicable. Strength reduction factors as given in ACI 318-11 D.4.4 must be used for load combinations set forth in ACI 318-11 Appendix C.

The value of f'_c used in the calculations must be limited to a maximum of 8,000 psi (55.2 MPa), in accordance with ACI 318-19 17.3.1, ACI 318-14 17.2.7 or ACI 318-11 D.3.7, as applicable.

4.1.2 Requirements for Static Steel Strength in Tension, N_{sa} : The nominal static steel strength of a single anchor in tension is calculated in accordance with ACI 318-19 17.6.1.2, ACI 318-14 17.4.1.2 or ACI 318-11 D.5.1.2, as applicable. The N_{sa} values of a single anchor are given in [Table 2](#) of this report. Strength reduction factors, ϕ , corresponding to brittle steel elements as defined in ACI 318 (-19 or -14) 2.3 or ACI 318-11 D.1, as applicable, and provided in [Table 2](#), must be used.

4.1.3 Requirements for Static Concrete Breakout Strength in Tension, N_{cb} or N_{cbg} : The nominal static concrete breakout strength for a single anchor or group of anchors in tension, N_{cb} or N_{cbg} , must be calculated in accordance with ACI 318-19 17.6.2, ACI 318-14 17.4.2 or ACI 318-11 D.5.2, as applicable, with modifications as described in this section. The basic concrete breakout strength in tension, N_b , must be calculated in accordance with ACI 318-19 17.6.2.2, ACI 318-14 17.4.2.2 or ACI 318-11 D.5.2.2, as applicable, using the values of h_{ef} and k_{cr} as given in [Table 2](#). The nominal concrete breakout strength in tension in regions of concrete where analysis indicates no cracking at service loads in accordance with ACI 318-19 17.6.2.5, ACI 318-14 17.4.2.6 or ACI 318-11 D.5.2.6, as applicable, must be calculated using the values of k_{uncr} as given in [Table 2](#) of this report with $\psi_{c,N} = 1.0$.

For $1/2$ -inch-diameter (12.7 mm) Tapcon+ Screw Anchors installed in the soffit of sand-lightweight or normalweight concrete on steel deck floor and roof assemblies, as shown in [Figure 6](#), calculation of the concrete breakout strength is not required.

4.1.4 Requirements for Static Pullout Strength in Tension, N_p : The nominal pullout strength of a single anchor in tension in accordance with ACI 318-19 17.6.3.1 and 17.6.3.2.1, ACI 318-14 17.4.3.1 and 17.4.3.2 or ACI 318-11 D.5.3.1 and D.5.3.2, as applicable, in cracked and uncracked concrete, $N_{p,cr}$ and $N_{p,uncr}$, respectively, is given in [Table 2](#) of this report. For all design cases $\Psi_{c,P} = 1.0$. In accordance with ACI 318-19 17.6.3, ACI 318-14 17.4.3 or ACI 318-11 D.5.3, as applicable, the nominal pullout strength in cracked concrete may be adjusted for concrete strengths according to Eq-1:

$$N_{p,f'c} = N_{p,cr} \left(\frac{f'_c}{2,500} \right)^n \quad (\text{lb,psi}) \quad (\text{Eq-1})$$

$$N_{p,f'c} = N_{p,cr} \left(\frac{f'_c}{17.2} \right)^n \quad (\text{N, MPa})$$

where f'_c is the specified compressive strength and n is the factor defining the influence of concrete strength on the pullout strength. For the $3/8$ -inch-diameter anchor in cracked concrete, n is 0.12. For all other diameters, n is 0.5.

In regions where analysis indicates no cracking in accordance with ACI 318-19 17.6.3.3, ACI 318-14 17.4.3.6 or ACI 318-11 D.5.3.6, as applicable, the nominal pullout strength in tension may be adjusted for concrete strengths according to Eq-2:

$$N_{p,f'c} = N_{p,uncr} \left(\frac{f'_c}{2,500} \right)^n \quad (\text{lb,psi}) \quad (\text{Eq-2})$$

$$N_{p,f'c} = N_{p,uncr} \left(\frac{f'_c}{17.2} \right)^n \quad (\text{N, MPa})$$

where f'_c is the specified compressive strength and n is the factor defining the influence of concrete strength on the pullout strength. For all diameters, n is 0.5.

Where values for $N_{p,cr}$ or $N_{p,uncr}$ are not provided in [Table 2](#), the pullout strength in tension need not be evaluated.

The nominal pullout strength in cracked concrete of the $1/2$ -inch-diameter (12.7 mm) Tapcon+ Screw Anchor installed in the soffit of sand-lightweight or normalweight concrete on steel deck floor and roof assemblies, as shown in [Figure 6](#), is given in [Table 5](#). In accordance with ACI 318-19 17.6.3.2.1, ACI 318-14 17.4.3.2 or ACI 318-11 D.5.3.2, as applicable, the nominal pullout strength in cracked concrete must be calculated in accordance with Eq-1, whereby the value of $N_{p,deck,cr}$ must be substituted for $N_{p,cr}$ and the value of 3,000 psi (20.7 MPa) must be substituted for the value of 2,500 psi (17.2 MPa) in the denominator. In regions where analysis indicates no cracking in accordance with ACI 318-19 17.6.3.3, ACI 318-14 17.4.3.6 or ACI 318-11 D.5.3.6, as applicable, the nominal strength in uncracked concrete must be calculated according to Eq-2, whereby the value of $N_{p,deck,uncr}$ must be substituted for $N_{p,uncr}$ and the value of 3,000 psi (20.7 MPa) must be substituted for the value of 2,500 psi (17.2 MPa) in the denominator.

4.1.5 Requirements for Static Steel Strength in Shear, V_{sa} : The nominal steel strength in shear, V_{sa} , of a single anchor in accordance with ACI 318-19 17.7.1.2, ACI 318-14 17.5.1.2 or ACI 318-11 D.6.1.2, as applicable, is given in [Table 3](#) of this report and must be used in lieu of the values derived by calculation from ACI 318-19 Eq. 17.7.1.2b, ACI 318-14 Eq. 17.5.1.2b or ACI 318-11, Eq. D-29, as applicable. Strength reduction factors, ϕ , corresponding to brittle steel elements as defined in ACI 318 (-19 or -14) 2.3 or ACI 318-11 D.1, as applicable, and provided in [Table 3](#), must be used.

The nominal shear strength $V_{sa,deck}$, of anchors installed in the soffit of sand-lightweight or normalweight concrete filled steel deck floor and roof assemblies, as shown in [Figure 6](#), is given in [Table 5](#).

4.1.6 Requirements for Static Concrete Breakout Strength of Anchor in Shear, V_{cb} or V_{cbg} : The nominal static concrete breakout strength of a single anchor or group of anchors in shear, V_{cb} or V_{cbg} , must be calculated in accordance with ACI 318-19 17.7.2, ACI 318-14 17.5.2 or ACI 318-11 D.6.2, as applicable, with modifications as described in this section. The basic concrete breakout strength of a single anchor in shear, V_b , must be calculated in accordance with ACI 318-19 17.7.2.2.1, ACI 318-14 17.5.2.2 or ACI 318-11 D.6.2.2, as applicable, based on the values provided in [Table 3](#). The value of l_e used in ACI 318-19 Eq. 17.7.2.2.1a, ACI 318-14 Eq. 17.5.2.2a or ACI 318-11 Eq. D-33, as applicable, must be taken as no greater than the lesser of h_{ef} or $8d_a$.

For $1/2$ -inch-diameter (12.7 mm) Tapcon+ Screw Anchors installed in the soffit of sand-lightweight or normalweight concrete on steel deck floor and roof assemblies, as shown in [Figure 6](#), calculation of the concrete breakout strength in shear is not required.

4.1.7 Requirements for Static Concrete Pryout Strength in Shear, V_{cp} or V_{cpg} : The nominal static concrete pryout strength of a single anchor or group of anchors in shear, V_{cp} or V_{cpg} , must be calculated in accordance with ACI 318-19 17.7.3, ACI 318-14 17.5.3 or ACI 318-11 D.6.3, as applicable, using the value of K_{cp} described in [Table 3](#), and the values of N_{cb} or N_{cbg} as calculated in Section 4.1.3 of this report.

For $1/2$ inch (12.7 mm) diameter Tapcon+ Screw Anchors installed in the soffit of sand-lightweight or normalweight concrete on steel deck floor and roof assemblies, as shown in [Figure 6](#), calculation of the concrete pryout strength in shear is not required.

4.1.8 Requirements for Seismic Design:

4.1.8.1 General: For load combinations including seismic, the design must be performed according to ACI 318-19 17.10, ACI 318-14 17.2.3 or ACI 318-11 D.3.3, as applicable. Modifications to ACI 318-19 17.10 or ACI 318-14 17.2.3 shall be applied under Section 1905.1.8 of the 2021, 2018 and 2015 IBC, as applicable. For the 2012 IBC, Section 1905.1.9 must be omitted.

The anchors comply with ACI 318 (-19 and -14) 2.3 or ACI 318-11 D.1, as applicable, as brittle steel elements and must be designed in accordance with ACI 318-19 17.10.5, 17.10.6, 17.10.7 or 17.10.4; ACI 318-14 17.2.3.4, 17.2.3.5, 17.2.3.6 or 17.2.3.7 or ACI 318-11 D.3.3.4, D.3.3.5, D.3.3.6 or D.3.3.7, as applicable.

The $1/4$ -inch-, $3/8$ -inch-, and $1/2$ -inch-diameter (6.4 mm, 9.5 mm, and 12.7 mm) Tapcon+ Screw Anchors may be installed in regions designated as IBC Seismic Design Categories A through F.

The $1/4$ -inch (6.4 mm) SAMMYS vertical threaded rod anchors (CCST 516) are limited to seismic tension loads only, and seismic shear loads are beyond the scope of this report. The $1/4$ -inch (6.4 mm) SAMMYS horizontal threaded rod anchors (SW-CCST 516) are limited to static shear loads only, and seismic tension or shear loads are beyond the scope of this report. The SAMMYS vertical threaded rod anchors (CCST 516) may be installed in regions designated as IBC Seismic Design Categories A through F.

4.1.8.2 Seismic Tension: The nominal steel strength and nominal concrete breakout strength for anchors in tension must be calculated according to ACI 318-19 17.6.1 and 17.6.2, ACI 318-14 17.4.1 and 17.4.2 or ACI 318-11 D.5.1 and D.5.2, respectively, as applicable, as described in Sections 4.1.2 and 4.1.3 of this report. In accordance with ACI 318-19 17.6.3.2.1, ACI 318-14 17.4.3.2 or ACI 318-11 D.5.3.2, as applicable, the value for nominal pullout strength in tension for seismic loads, $N_{p,eq}$ or $N_{p,deck,cr}$, given in [Table 2](#) and [Table 5](#) of this report, must be used in lieu of N_p . The values of $N_{p,eq}$ or $N_{p,deck,cr}$ must be adjusted for the concrete strength in accordance with Eq-2 and Section 4.1.4 whereby the value of $N_{p,deck,cr}$ must be substituted for $N_{p,cr}$ and the value of 3,000 psi (20.7 MPa) must be substituted for the value of 2,500 psi (17.2 MPa) in the denominator. If no values for $N_{p,eq}$ are given in [Table 2](#) or [Table 5](#), the static design strength values govern.

4.1.8.3 Seismic Shear: The nominal concrete breakout strength and pryout strength for anchors in shear must be calculated according to ACI 318-19 17.7.2 and 17.7.3, ACI 318-14 17.5.2 and 17.5.3 or ACI 318-11 D.6.2 and D.6.3, respectively, as applicable, as described in Sections 4.1.6 and 4.1.7 of this report. In accordance with ACI 318-19 17.7.1.2, ACI 318-14 17.5.1.2 or ACI 318-11 D.6.1.2, as applicable, the value for nominal steel strength in shear for seismic loads, $V_{sa,eq}$, or $V_{sa,deck}$, given in [Tables 3](#) or [5](#) of this report, must be used in lieu of V_{sa} , as applicable.

4.1.9 Requirements for Interaction of Tensile and Shear Forces: For designs that include combined tension and shear, the interaction of tension and shear loads must be calculated in accordance with ACI 318-19 17.8, ACI 318-14 17.6 or ACI 318-11 D.7, as applicable. For the Sammys anchors, influence of bending on tension values when loaded in shear must be considered.

4.1.10 Requirements for Critical Edge Distance: In applications where $c < c_{ac}$ and supplemental reinforcement to control splitting of the concrete is not present, the concrete breakout strength in tension for uncracked concrete, calculated in accordance with ACI 318-19 17.6.2, ACI 318-14 17.4.2 or ACI 318-11 D.5.2, as applicable, must be further multiplied by the factor $\psi_{cp,N}$ given by Eq-3:

$$\psi_{cp,N} = \frac{c}{c_{ac}} \quad (\text{Eq-3})$$

whereby the factor $\psi_{cp,N}$ need not be taken as less than $\frac{1.5h_{ef}}{c_{ac}}$. For all other cases, $\psi_{cp,N} = 1.0$. In lieu of ACI 318-19 17.9.5, ACI 318-14 17.7.6 or ACI 318-11 D.8.6, as applicable, the values for the critical edge distance, c_{ac} , must be taken from [Table 1](#).

4.1.11 Requirements for Minimum Member Thickness, Minimum Anchor Spacing and Minimum Edge Distance: In lieu of ACI 318-19 17.9.2, ACI 318-14 17.7.1 and 17.7.3 or ACI 318-11 D.8.1 and D.8.3, respectively, as applicable, values of s_{min} and c_{min} as given in [Table 1](#) of this report must be used. In lieu of ACI 318-19 17.9.4, ACI 318-14 17.7.5 or ACI 318-11 D.8.5, minimum concrete thickness h_{min} as given in [Table 1](#) of this report must be used.

For $1/2$ -inch-diameter (12.7 mm) Tapcon+ Screw Anchors installed in the soffit of sand-lightweight or normalweight concrete on steel deck floor and roof assemblies, the anchors must be installed in accordance with [Figure 6](#) and must have an axial spacing along the flute equal to the greater of $3h_{ef}$ or 1.5 times the flute width.

4.1.12 Lightweight Concrete: For the use of anchors in lightweight concrete, the modification factor λ_a equal to 0.8 λ is applied to all values of $\sqrt{f'_c}$ affecting N_n and V_n .

For ACI 318-19 (2021 IBC), ACI 318-14 (2018 and 2015 IBC) and ACI 318-11 (2012 IBC), λ shall be determined in accordance with the corresponding version of ACI 318.

For anchors installed in the soffit of sand-lightweight concrete-filled steel deck and floor and roof assemblies, further reduction of the pullout values provided in this report is not required.

4.2 Allowable Stress Design:

4.2.1 General: Design values for use with allowable stress design (working stress design) load combinations calculated in accordance with Section 1605.1 of the 2021 IBC or Section 1605.3 of the 2018, 2015 and 2012 IBC, must be established as follows:

$$T_{allowable,ASD} = \frac{\phi N_n}{\alpha} \quad (\text{Eq-4})$$

$$V_{allowable,ASD} = \frac{\phi V_n}{\alpha} \quad (\text{Eq-5})$$

where:

$T_{allowable, ASD}$ = Allowable tension load (lbf or kN).

$V_{allowable, ASD}$ = Allowable tension load (lbf or kN).

ϕN_n = Lowest design strength of an anchor or anchor group in tension as determined in accordance with ACI 318 (-19 and -14) Chapter 17 and 2021, 2018 and 2015 IBC Section 1905.1.8, ACI 318-11 Appendix D, and Section 4.1 of this report, as applicable (lbf or kN). For the 2012 IBC, Section 1905.1.9 must be omitted.

- ϕV_n = Lowest design strength of an anchor or anchor group in shear as determined in accordance with ACI 318 (-19 and -14) Chapter 17 and 2021, 2018 and 2015 IBC Section 1905.1.8, ACI 318-11 Appendix D, and Section 4.1 of this report, as applicable (lbf or kN). For the 2012 IBC, Section 1905.1.9 must be omitted.
- α = Conversion factor calculated as a weighted average of the load factors for the controlling load combination. In addition, α must include all applicable factors to account for nonductile failure modes and required over-strength.

Limits on edge distance, anchor spacing and member thickness as given in Section 4.1.11 of this report must apply. An illustrative example of allowable stress design values is shown in [Table 4](#).

4.2.2 Interaction of Tensile and Shear Forces: The interaction must be calculated and consistent with ACI 318-19 17.8, ACI 318-14 17.6 or ACI 318-11 D.7, as applicable, as follows:

If $T_{applied} \leq 0.2 T_{allowable,ASD}$, the full allowable load in shear $V_{allowable,ASD}$ shall be permitted.

If $V_{applied} \leq 0.2 V_{allowable,ASD}$, the full allowable load in tension $T_{allowable,ASD}$ shall be permitted.

For all other cases:

$$\frac{T_{applied}}{T_{allowable,ASD}} + \frac{V_{applied}}{V_{allowable,ASD}} \leq 1.2 \quad (\text{Eq-6})$$

4.3 Installation:

Installation parameters are provided in [Table 1](#) and [Figures 4](#) and [6](#) of this report. The Tapcon+ Screw Anchors and SAMMYS Anchors must be installed in accordance with the manufacturer's published instructions and this report. In case of conflict, this report governs. Anchor locations must comply with this report and the plans and specifications approved by the code official.

4.3.1 Tapcon+ Screw Anchors with Advanced Threadform Technology: $1/4$ -inch-, $3/8$ -inch-, and $1/2$ -inch-diameter (6.4 mm, 9.5 mm, and 12.7 mm) Tapcon+ Screw Anchors must be installed according to ITW's published instructions and this report. For the $1/4$ -inch-diameter (6.4 mm) anchor, the holes must be predrilled in concrete with a carbide-tipped drill bit complying with ANSI B212.15-1994 or a Tapcon+ carbide-tipped drill bit, supplied by ITW. For the $3/8$ -inch- and $1/2$ -inch-diameter (9.5 mm and 12.7 mm) anchors, the holes must be predrilled in concrete with a carbide-tipped drill bit complying with ANSI B212.15-1994. The hole must be drilled to the specified minimum hole depth, h_{hole} , in accordance with [Table 1](#). Before anchor installation, dust and other debris must be removed by use of a vacuum or compressed air. The anchors must then be installed through the attachment into the hole, in accordance with ITW's instructions, to the specified nominal embedment depth using a powered impact wrench or manual torque wrench until the proper embedment depth is obtained. The maximum impact wrench torque and maximum installation torque for the manual torque wrench must be in accordance with [Table 1](#). The Tapcon+ Screw Anchors may be loosened by a maximum of one turn and retightened with a manual torque wrench or powered impact wrench to facilitate fixture attachment or realignment. Complete removal and reinstallation of the anchor is not allowed.

For installation of the $1/2$ -inch-diameter (12.7 mm) Tapcon+ Screw Anchor in the soffit of concrete on steel deck assemblies, the hole diameter in the steel deck must not exceed the diameter of the hole in the concrete by more than $1/8$ inch (3.2 mm). For member thickness and edge distance restrictions for installations into the soffit of concrete on steel deck assemblies, see [Figure 6](#).

4.3.2 SAMMYS Anchors for Threaded Rod: The SAMMYS Anchors must be installed according to ITW's published instructions and this report. Holes must be predrilled in concrete with a Tapcon carbide-tipped drill bit complying with ANSI B212.15-1994, supplied by ITW. The hole must be drilled to the specified nominal embedment depth plus a minimum of $1/4$ inch (6.4 mm). Before anchor installation, dust and other debris must be removed by use of a vacuum or compressed air. The anchors must then be installed into the hole, in accordance with ITW's instructions, to the specified nominal embedment depth using a powered impact wrench in conjunction with the ITW torque limiting nut driver until the proper embedment depth is obtained. Removal and reinstallation of the anchor is not allowed.

4.4 Special Inspection:

Periodic special inspection is required in accordance with Section 1705.1.1 and Table 1705.3 of the 2021, 2018, 2015 and 2012 IBC, as applicable. The special inspector must make periodic inspections during anchor installation to verify anchor type, anchor dimensions, concrete type, concrete compressive strength, hole

dimensions, anchor spacing, edge distances, concrete thickness, anchor embedment, drill bit type and size, hole cleaning procedures, installation torque, and adherence to the manufacturer's published installation instructions and the conditions of this report (in case of conflict, this report governs). The special inspector must be present as often as required in accordance with the "statement of special inspection."

5.0 CONDITIONS OF USE:

The Tapcon+ Screw Anchors and SAMMYS Anchors described in this report are suitable alternatives to what is specified in, those codes listed in Section 1.0 of this report, subject to the following conditions:

- 5.1 Anchor sizes, dimensions, embedment, and installation are as set forth in this report.
- 5.2 The anchors must be installed in accordance with the manufacturer's published installation instructions and this report. In case of conflict, this report governs.
- 5.3 The 1/4-inch-, 3/8-inch-, and 1/2-inch-diameter (6.4 mm, 9.5 mm and 12.7 mm) anchors must be used in cracked and uncracked normalweight concrete and lightweight concrete having a specified compressive strength, f'_c , of 2,500 psi to 8,500 psi (17.2 MPa to 58.6 MPa).
- 5.4 The 1/2-inch-diameter (12.7 mm) anchor may be used in cracked and uncracked normalweight or sand-lightweight concrete over metal deck having a minimum specified compressive strength, f'_c , of 3,000 psi (20.7 MPa).
- 5.5 The values of f'_c used for calculation purposes must not exceed 8,000 psi (55.1 MPa).
- 5.6 The concrete shall have attained its minimum design strength prior to installation of the anchors.
- 5.7 Strength design values must be established in accordance with Section 4.1 of this report.
- 5.8 Allowable stress design values must be established in accordance with Section 4.2 of this report.
- 5.9 Anchor spacing, edge distance, and minimum concrete thickness must comply with Section 4.1.11, [Table 1](#), and [Figure 6](#) of this report.
- 5.10 Reported values for the SAMMYS Anchors for Threaded Rod do not consider the steel element threaded into the anchor, which must be verified by the design professional. SAMMYS Anchors must be installed directly into the concrete, without the use of a baseplate.
- 5.11 Prior to installation, calculations and details demonstrating compliance with this report must be submitted to the code official for approval. The calculations and details must be prepared by a registered design professional where required by the statutes of the jurisdiction in which the project is to be constructed.
- 5.12 Since an ICC-ES acceptance criteria for evaluating data to determine the performance of anchors subjected to fatigue or shock loading is unavailable at this time, the use of these anchors under these conditions is beyond the scope of this report.
- 5.13 The 1/4-inch-, 3/8-inch-, and 1/2-inch-diameter (6.4 mm, 9.5 mm, and 12.7 mm) Tapcon+ Screw Anchors may be used to resist short-term loading due to wind forces and for seismic load combinations in locations designated as Seismic Design Categories A through F under the IBC, subject to the conditions of this report.
- 5.14 The 1/4-inch-diameter (6.4 mm) SAMMYS Anchors may be used to resist short-term loading due to wind forces and seismic tension loads only in locations designated as Seismic Design Categories A through F under the IBC, subject to the conditions of this report.
- 5.15 Anchors are not permitted to support fire-resistance-rated construction. Where not otherwise prohibited by the code, anchors are permitted for installation in fire-resistance-rated construction provided that at least one of the following conditions is fulfilled:
 - Anchors are used to resist wind or seismic forces only.
 - Anchors that support a fire-resistance-rated envelope or a fire-resistance-rated membrane, are protected by approved fire-resistance-rated materials, or have been evaluated for resistance to fire exposure in accordance with recognized standards.
 - Anchors are used to support nonstructural elements.
- 5.16 The anchors have been evaluated for reliability against brittle failure and found to be not significantly sensitive to stress-induced hydrogen-embrittlement.

- 5.17 The design of anchor groups in accordance with ACI 318 (-19 and -14) Chapter 17 or ACI 318-11 Appendix D, as applicable, is valid for screw anchors with a thread length of at least 80 percent of the nominal embedment depth. Anchors with a thread length less than 80 percent of the nominal embedment depth shall be designed as single anchors.
- 5.18 Use of anchors must be limited to dry, interior locations.
- 5.19 Special inspection must be provided in accordance with Section 4.4 of the report.
- 5.20 Anchors are manufactured in the U.S.A. under an approved quality-control program with inspections by ICC-ES.

6.0 EVIDENCE SUBMITTED

Data in accordance with the [ICC-ES Acceptance Criteria for Mechanical Anchors in Concrete Elements \(AC193\)](#), dated October 2017 (editorially revised December 2020); and quality-control documentation.

7.0 IDENTIFICATION

7.1 The Tapcon+ Screw Anchors and SAMMYS Anchors are identified by packaging labeled with the manufacturer’s name (ITW Red Head, ITW Buildex, or ITW Brands), contact information, anchor name, anchor size, and evaluation report number (ESR-3699). The Red Head logo or “BX” logo, and a length identification code letter are stamped on the head of each anchor. See the length identification system illustrated in [Figure 2](#) of this report.

7.2 The report holder’s contact information is the following:

ITW RED HEAD
ITW BUILDEX
155 HARLEM AVENUE
GLENVIEW, ILLINOIS 60025
(800) 848-5611
www.itw-redhead.com
techsupport@itwccna.com

7.3 The Additional Listee’s contact information is the following:

ITW BRANDS
155 HARLEM AVENUE
GLENVIEW, ILLINOIS 60025
(877) 489-2726
www.itwbrands.com

TABLE A—PRODUCT IDENTIFICATION CROSS REFERENCE BY MANUFACTURER

PRODUCT REFERENCE PER ICC-ES ESR-3699	ITW RED HEAD	ITW BUILDEX	ITW BRANDS
1/4" SAMMYS for Vertical Rod	Not applicable	1/4" SAMMYS for Vertical Rod Part No. CCST 516	Not applicable
1/4" SAMMYS for Horizontal Rod	Not applicable	1/4" SAMMYS for Horizontal Rod Part No. SW-CCST 516	Not applicable
1/4" Tapcon+ Anchor	1/4" Tapcon+ Anchor	Not applicable	Buildex 5/16" Tapcon+ Anchor
3/8" Tapcon+ Anchor	3/8" Tapcon+ Anchor	Not applicable	Buildex 3/8" Tapcon+ Anchor
1/2" Tapcon+ Anchor	1/2" Tapcon+ Anchor	Not applicable	Buildex 1/2" Tapcon+ Anchor



FIGURE 1—TAPCON+ SCREW ANCHOR WITH ADVANCED THREADFORM TECHNOLOGY

LENGTH MARKING ON ANCHOR HEAD			A	B	C	D	E	F	G	H	I	J
Length of anchor (inches)	From	1	1 ¹ / ₂	2	2 ¹ / ₂	3	3 ¹ / ₂	4	4 ¹ / ₂	5	5 ¹ / ₂	6
	Up to, but not including	1 ¹ / ₂	2	2 ¹ / ₂	3	3 ¹ / ₂	4	4 ¹ / ₂	5	5 ¹ / ₂	6	6 ¹ / ₂

For SI: 1 inch = 25.4 mm.

FIGURE 2—LENGTH IDENTIFICATION SYSTEM



SAMMYS Vertical Threaded Rod Anchor (Model No. CCST 516) with torque-limiting nut driver (#14 Black Nut Driver)

SAMMYS Horizontal Threaded Rod Anchor (Model No. SW-CCST 516) with torque-limiting nut driver (#14 SW Red Nut Driver)

FIGURE 3—SAMMYS SCREW ANCHORS FOR THREADED ROD



INSTALLATION INSTRUCTIONS FOR TAPCON+ SCREW ANCHORS

Installation Steps for Concrete, Lightweight Concrete and Metal Deck



1. Using a carbide drill bit, drill a hole at least 1/4" deeper than anchor embedment.

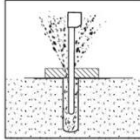

2. Clean hole with pressurized air or vacuum to remove any excess dust/debris.

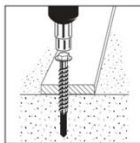

3. Using an impact or manual wrench, insert anchor into hole and tighten anchor until fully seated.

ANCHOR DIAMETER (inch)	ANSI DRILL BIT DIAMETER (inch) ¹	ANCHOR HEAD (SOCKET SIZE) DIAMETER (inch)	ANCHOR HEAD HEIGHT (inch)	WASHER DIAMETER (inch)	MANUAL WRENCH MAX TORQUE ²	IMPACT WRENCH MAX TORQUE RATING
¹ / ₄ (ITW Red Head Anchor)	¹ / ₄	³ / ₈	0.24	¹ / ₂	20 FT LBS	115 FT LBS
⁵ / ₁₆ (ITW Brands Anchor)	¹ / ₄	³ / ₈	0.24	¹ / ₂	20 FT LBS	115 FT LBS
³ / ₈	³ / ₈	⁹ / ₁₆	0.35	¹³ / ₁₆	50 FT LBS	200 FT LBS
¹ / ₂	¹ / ₂	³ / ₄	0.45	1	70 FT LBS	345 FT LBS

¹ A ¹/₄-inch Tapcon+ drill bit may also be used for installation of the ¹/₄-inch anchor.

² For manual installation, use a torque wrench to verify that the maximum installation torque has not been exceeded.



Installation Steps for Concrete

1. Using a ¹/₄-inch Tapcon+ drill bit, drill a hole at least ¹/₄-inch deeper than anchor embedment.
2. Clean hole with compressed air or vacuum to remove any excess dust/debris.
3. Insert appropriate torque-limiting nut driver into the drill. See chart below.
4. Insert the anchor into the nut driver, position the anchor into hole and tighten anchor until nut driver spins free on cap of anchor.

Anchor Model	Torque-Limiting Nut Driver (Color)	Installation Orientation	Rod Size (inch)
CCST 516	#14 (Black)	Vertical	³ / ₈
SW-CCST 516	#14 SW (Red)	Horizontal	³ / ₈

FIGURE 4—INSTALLATION INSTRUCTIONS FOR TAPCON+ SCREW ANCHOR AND SAMMYS THREADED ROD ANCHOR

TABLE 1—INSTALLATION INFORMATION FOR TAPCON+ SCREW ANCHORS AND SAMMYS THREADED ROD ANCHORS^{1,5}

CHARACTERISTIC	SYMBOL	UNITS	NOMINAL ANCHOR DIAMETER (inch)						
			1/4		1/4	3/8	1/2		
Head Style	—	—	SAMMYS for Vertical Rod (CCST 516)	SAMMYS for Horizontal Rod (SW-CCST 516)	Hex Head	Hex Head	Hex Head		
Nominal Outside diameter (Shank)	d_a	in.	0.25		0.25	0.38	0.50		
Nominal Outside diameter (threads)	—	in.	0.33		0.33	0.46	0.59		
Drill bit specification	d_{bit}	in.	1/4 Tapcon+ Bit		1/4 Tapcon+ Bit	1/4 ANSI Bit	3/8 ANSI Bit	1/2 ANSI Bit	
Minimum base plate clearance hole diameter	d_h	in.	Not applicable ²		3/8	1/2	5/8		
Maximum installation torque ⁴	$T_{inst, max}$	ft-lbf	Not applicable ³		20	50	70		
Maximum Impact Wrench Torque Rating	$T_{impact, max}$	ft-lbf	Not applicable ³		115	200	345		
Effective embedment depth	h_{ef}	in.	1.67		1.45	1.78	1.32	2.17	3.02
Minimum nominal embedment depth ⁵	h_{nom}	in.	2 1/4		2	2 1/2	2	3	4
Minimum hole depth	h_{hole}	in.	2 1/2		2 1/4	2 3/4	2 1/4	3 1/4	4 1/4
Minimum concrete member thickness	h_{min}	in.	4		4	4	4	6	
Critical edge distance	c_{ac}	in.	2 1/2		2 1/2	4 1/2	3	4	5
Minimum edge distance	c_{min}	in.	1 1/2		1 1/2	1 1/2	2 1/2	3 1/4	2 1/2
Minimum spacing	s_{min}	in.	3		3	3	3	3 1/2	3

For **SI**: 1 inch = 25.4 mm, 1 ft-lbf = 1.356 N-m.

¹The data presented in this table is to be used in conjunction with the design criteria of ACI 318-19 Chapter 17, ACI 318-14 Chapter 17 or ACI 318-11 Appendix D, as applicable.

²The Sammys Anchor is installed without a base plate, directly into the concrete.

³Installation must be performed with an ITW torque limiting nut driver, as applicable. See Section 4.3 for additional information.

⁴ $T_{inst, max}$ applies to installations using a calibrated torque wrench.

⁵For the 3/8-inch-, and 1/2-inch-diameter Tapcon+ anchors, the design of anchor groups in accordance with ACI 318 (-19 and -14) Chapter 17 or ACI 318-11 Appendix D, as applicable, is only valid for screw anchors with a thread length of at least 80 percent of the nominal embedment depth. Anchors with a thread length less than 80 percent of the nominal embedment depth shall be designed as single anchors.

TABLE 2—TENSION STRENGTH DESIGN INFORMATION FOR TAPCON+ SCREW ANCHORS AND SAMMYS THREADED ROD ANCHORS¹

CHARACTERISTIC	SYMBOL	UNITS	NOMINAL ANCHOR DIAMETER (inch)							
			1/4		1/4		3/8	1/2		
Head Style	—	—	SAMMYS for Vertical Rod (CCST 516)	SAMMYS for Horizontal Rod (SW-CCST 516)	Hex Head		Hex Head	Hex Head		
Drill bit specification		in.	1/4 Tapcon+ Bit		1/4 Tapcon+ Bit	1/4 ANSI Bit	3/8 ANSI Bit	1/2 ANSI Bit		
Anchor category	1, 2 or 3	—	1		1	2	1	1		
Effective embedment depth	h_{ef}	in.	1.45 ⁴		1.45		1.78	1.32	2.17	3.02
Minimum concrete member thickness	h_{min}	in.	4		4		4	4	6	
Critical edge distance	c_{ac}	in.	2 1/2		2 1/2		4 1/2	3	4	5
Data for Steel Strength in Tension										
Minimum specified yield strength	f_y	psi	Not applicable		100,000		100,000	100,000		
Minimum specified ultimate strength	f_{uta}	psi	Not applicable		125,000		125,000	125,000		
Effective tensile stress area	A_{se}	in ²	Not applicable		0.0470		0.098	0.1850		
Steel strength in tension	N_{sa}	lbf	1,822 ⁵		5,900		12,250	23,125		
Strength reduction factor ϕ for tension, steel failure modes ²	ϕ_{sa}	—	0.65		0.65		0.65	0.65		
Data for Concrete Breakout Strength in Tension										
Effectiveness factor - uncracked concrete	k_{uncr}	—	24		24		27	30		
Effectiveness factor - cracked concrete	k_{cr}	—	17		17		17	17		
Modification factor for cracked and uncracked concrete	$\psi_{c,N}$	—	1.0		1.0		1.0	1.0		
Strength reduction factor ϕ for tension, concrete failure modes ²	ϕ_{cb}	—	0.65		0.65	0.55	0.65	0.65		
Data for Pullout Strength in Tension										
Pullout strength, uncracked concrete	$N_{p,uncr}$	lbf	2,107		2,107		See Footnote 3	See Footnote 3		
Pullout strength, cracked concrete	$N_{p,cr}$	lbf	857		857		1,837	See Footnote 3		
Pullout strength for seismic loads	$N_{p,eq}$	lbf	857		857		1,677	See Footnote 3		
Strength reduction factor ϕ for tension, pullout failure modes ²	ϕ_p	—	0.65		0.65	0.55	0.65	See Footnote 3		
Additional Anchor Data										
Axial stiffness in service load range in uncracked concrete	β_{uncr}	lbf /in	385,000		385,000		800,000	800,000		
Axial stiffness in service load range in cracked concrete	β_{cr}	lbf /in	225,000		225,000		365,000	365,000		

For SI: 1 inch = 25.4 mm, 1 ft-lbf = 1.356 N-m.

¹The data presented in this table is to be used in conjunction with the design criteria of ACI 318 (-19 and -14) Chapter 17 or ACI 318-11 Appendix D, as applicable.

²The strength reduction factor applies when the load combinations from the IBC or ACI 318 are used and the requirements of ACI 318-19 17.5.3, ACI 318-14 17.3.3 or ACI 318-11 D.4.3, as applicable, are met. If the load combinations of ACI 318-11 Appendix C are used, the appropriate strength reduction factor must be determined in accordance with ACI 318-11 D.4.4.

³Pullout resistance does not govern design and does not need to be considered.

⁴For calculation only. For actual h_{ef} see [Table 1](#).

⁵For the strength between the threaded cap and anchor head.

**TABLE 3—SHEAR STRENGTH DESIGN INFORMATION FOR TAPCON+ SCREW ANCHORS
AND SAMMYS THREADED ROD ANCHORS¹**

CHARACTERISTIC	SYMBOL	UNITS	NOMINAL ANCHOR DIAMETER (inch)							
			$\frac{1}{4}$		$\frac{1}{4}$	$\frac{3}{8}$	$\frac{1}{2}$			
Head Style	—	—	SAMMYS for Vertical Rod (CCST 516)	SAMMYS for Horizontal Rod (SW-CCST 516)	Hex Head		Hex Head	Hex Head		
Drill bit specification		in.	$\frac{1}{4}$ Tapcon+ Bit		$\frac{1}{4}$ Tapcon+ Bit	$\frac{1}{4}$ ANSI Bit	$\frac{3}{8}$ ANSI Bit	$\frac{1}{2}$ ANSI Bit		
Anchor category	1, 2 or 3	—	1		1	2	1	1		
Minimum effective embedment depth	h_{ef}	in.	1.45 ⁴		1.45		1.78	1.32	2.17	3.02
Minimum concrete member thickness	h_{min}	in.	4		4		4	4	6	
Critical edge distance	c_{ac}	in.	2 $\frac{1}{2}$		2 $\frac{1}{2}$		4 $\frac{1}{2}$	3	4	5
Data for Steel Strengths in Shear										
Minimum specified yield strength	f_y	psi	Not applicable		100,000		100,000	100,000		
Minimum specified ultimate strength	f_{uta}	psi	Not applicable		125,000		125,000	125,000		
Effective shear stress area	A_{se}	in ²	Not applicable		0.047		0.098	0.185		
Steel strength in shear - static	V_{sa}	lbf	905 ⁵		2,045		3,621	12,610		
Steel strength in shear - seismic	$V_{sa,eq}$		Not applicable ³		1,350		2,920	9,300		
Strength reduction factor ϕ for shear, steel failure modes ²	ϕ_{sa}	—	0.60		0.60		0.60	0.60		
Data for Concrete Breakout and Concrete Pryout Strengths in Shear										
Nominal Outside diameter (shank)	d_a	in.	0.25		0.25		0.38	0.50		
Load bearing length of anchor	l_e	—	1.67		1.45		1.78	1.32	2.17	3.02
Coefficient for Pryout Strength	κ_{cp}	—	1.0		1.0		1.0	1.0		2.0
Strength reduction factor for shear, concrete breakout ²	ϕ_{cb}	—	0.70		0.70		0.70	0.70		
Strength reduction factor for shear, pryout ²	ϕ_{cp}	—	0.70		0.70		0.70	0.70		

For **SI**: 1 inch = 25.4 mm, 1 ft-lbf = 1.356 N-m.

¹The data presented in this table is to be used in conjunction with the design criteria of ACI 318-14 Chapter 17 or ACI 318-11 Appendix D, as applicable.

²The strength reduction factor applies when the load combinations from the IBC or ACI 318 are used and the requirements of ACI 318-19 17.5.3, ACI 318-14 17.3.3 or ACI 318-11 D.4.3, as applicable, are met. If the load combinations of ACI 318-11 Appendix C are used, the appropriate strength reduction factor must be determined in accordance with ACI 318-11 D.4.4.

³The SAMMYS anchors have not been evaluated for seismic shear design under this report.

⁴For calculation only. For actual h_{ef} see [Table 1](#).

⁵For the strength between the threaded cap and anchor head.

TABLE 4—EXAMPLE ALLOWABLE STRESS DESIGN TENSION VALUES FOR ILLUSTRATIVE PURPOSES FOR TAPCON+ SCREW ANCHORS AND SAMMYS THREADED ROD ANCHORS ^{1,2,3,4,5,6,7,8,9}

NOMINAL ANCHOR DIAMETER (inch)	NOMINAL EMBEDMENT DEPTH (inches)	EFFECTIVE EMBEDMENT DEPTH (inches)	ALLOWABLE TENSION LOAD (pounds)
1/4 SAMMYS	2.25	1.45 ¹⁰	800
1/4	2.00	1.45	920
3/8	2.50	1.78	1,335
1/2	2.00	1.32	800
	3.00	2.17	1,685
	4.00	3.02	2,765

For SI: 1 inch = 25.4 mm, 1 lbf = 4.45 N, 1 psi = 0.006895 MPa.

¹Single anchor with static tension load only.

²Concrete determined to remain uncracked for the life of the anchorage.

³Load combination from ACI 318 (-19 and -14) Section 5.3 or ACI 318-11 Section 9.2, as applicable, (no seismic loading).

⁴30 percent dead load and 70 percent live load, controlling load combination 1.2D + 1.6L.

⁵Calculation of weighted average for $\alpha = 0.3 \cdot 1.2 + 0.7 \cdot 1.6 = 1.48$.

⁶Normalweight concrete, $f'_c = 2,500$ psi

⁷ $C_{a1} = C_{a2} > C_{ac}$.

⁸ $h \geq h_{min}$.

⁹Condition B where supplementary reinforcement in accordance with ACI 318-19 17.5.3, ACI 318-14 Section 17.3.4 or ACI 318-11 Section D.4.4, as applicable, is not provided.

¹⁰For calculation only. For actual h_{ef} see [Table 1](#).

Illustrative Procedure to Calculate Allowable Stress Design Tension Value:

Tapcon+ Screw Anchor 1/2-inch diameter, using an embedment of 4-inches, assuming the conditions given in [Table 4](#).

	PROCEDURE	CALCULATION
Step 1	Calculate steel strength of a single anchor in tension per ACI 318-19 17.6.1.2, ACI 318-14 17.4.1.2, ACI 318-11 D 5.1.2, Table 2 of this report:	$\phi N_{sa} = \phi N_{sa}$ $= 0.70 \cdot 23,125$ =15,031 lbs steel strength
Step 2	Calculate concrete breakout strength of a single anchor in tension per ACI 318-19 17.6.2.2, ACI 318-14 17.4.2.2, ACI 318-11 D 5.2.2, Table 2 of this report:	$N_b = k_{uncr} \sqrt{f'_c} h_{ef}^{1.5}$ $= 24 \cdot \sqrt{2,500} \cdot 3.02^{1.5}$ $= 6,298$ lbs $\phi N_{cb} = \phi A_{NC}/A_{NCO} \psi_{ed,N} \psi_{c,N} \psi_{cp,N} N_b$ $= 0.65 \cdot 1.0 \cdot 1.0 \cdot 1.0 \cdot 1.0 \cdot 6,298$ $= 0.65 \cdot 6,298$ = 4,093 lbs concrete breakout strength
Step 3	Calculate pullout strength per Table 2 of this report:	$\phi N_{pn} = \phi N_{p,uncr} \psi_{c,P}$ n/a – pullout strength does not control (see Table 2, footnote 4)
Step 4	Determine controlling resistance strength in tension per ACI 318-19 17.5.2, ACI 318-14 17.3.1.1, ACI 318-11 D 4.1.1:	= 4,093 lbs controlling resistance (concrete)
Step 5	Calculate allowable stress design conversion factor for loading condition per ACI 318-19 and ACI 318-14 Section 5.3, or ACI 318-11 Section 9.2:	$\alpha = 1.2D + 1.6L$ $= 1.2(0.3) + 1.6(0.7)$ =1.48
Step 6	Calculate allowable stress design value per Section 4.2 of this report:	$T_{allowable,ASD} = \phi N_n / \alpha$ $= 4,093 / 1.48$ = 2,765 lbs allowable stress design

FIGURE 5—EXAMPLE DESIGN CALCULATION

Nominal Anchor Diameter = 1/2"

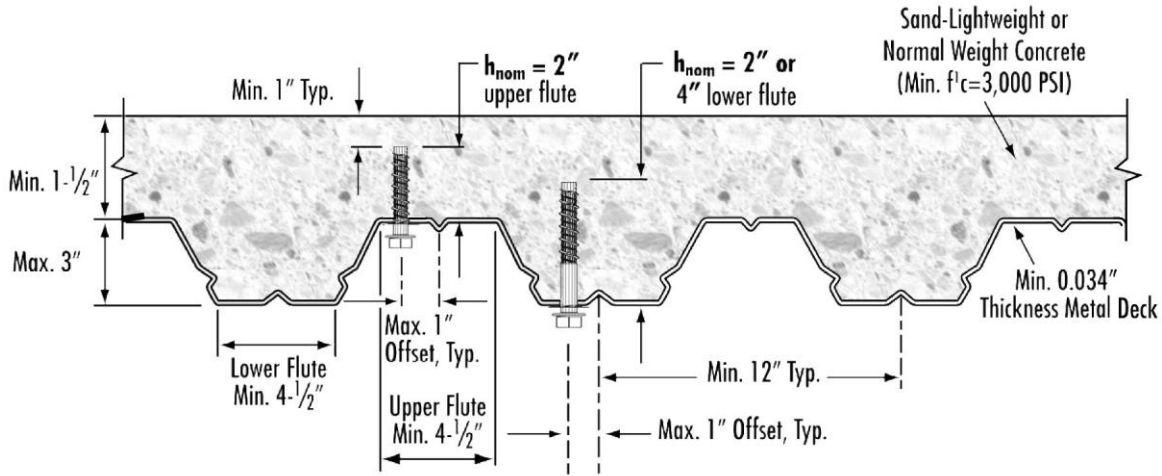

FIGURE 6—TAPCON+ SCREW ANCHOR LOCATED IN THE SOFFIT OF CONCRETE OVER STEEL DECK FLOOR AND ROOF ASSEMBLIES (1 inch = 25.4 mm)

TABLE 5—TAPCON+ SCREW ANCHOR DESIGN INFORMATION FOR ANCHORS LOCATED IN THE SOFFIT OF CONCRETE OVER STEEL DECK FLOOR AND ROOF ASSEMBLIES^{1,2,3,4,5}

CHARACTERISTIC	SYMBOL	UNITS	NOMINAL ANCHOR DIAMETER (inch)		
			1/2		
Location of installation	—	—	Lower Flute	Upper Flute	
Minimum hole depth	h_{hole}	in.	2 1/2	4 1/2	2 1/2
Nominal embedment depth	h_{nom}	in.	2	4	2
Minimum effective embedment depth	h_{ef}	in.	1.32	3.02	1.32
Characteristic pullout strength, uncracked concrete over metal deck	$N_{p, deck, uncr}$	lbf	1,720	4,950	2,405
Characteristic pullout strength, cracked concrete over metal deck	$N_{p, deck, cr}$	lbf	975	2,805	1,360
Characteristic shear strength, concrete over metal deck	$V_{sa, deck}$	lbf	3,825	6,130	3,825
Characteristic shear strength - seismic, concrete over metal deck	$V_{sa, deck, eq}$	lbf	2,820	4,520	2,820
Reduction factor for pullout strength in tension	ϕ	—	0.65		
Reduction factor for steel strength in shear	ϕ	—	0.60		

For **SI**: 1 inch = 25.4 mm, 1 ft-lbf = 1.356 N-m.

¹Values for $N_{p, dec, uncr}$, $N_{p, dec, cr}$, $V_{sa, deck}$ and $V_{sa, deck, eq}$ apply to sand-lightweight concrete having a minimum concrete compressive strength, f'_c , of 3,000 psi.

²The characteristic pull-out strength for greater concrete compressive strengths shall be increased by multiplying the tabular value by $(f'_c/3,000 \text{ psi})^{0.5}$.

³The strength reduction factor applies when the load combinations from the IBC or ACI 318 are used and the requirements of ACI 318-19 17.5.3, ACI 318-14 17.3.3 or ACI 318-11 D.4.3, as applicable, are met. If the load combinations of ACI 318-11 Appendix C are used, the appropriate strength reduction factor must be determined in accordance with ACI 318-11 D.4.4.

⁴The minimum anchor spacing along the flute must be the greater of $3h_{ef}$ or 1.5 times the flute width in accordance with Section 4.1.11 of this report.

⁵Installation must comply with [Figure 6](#) of this report.

DIVISION: 03 00 00—CONCRETE

Section: 03 16 00—Concrete Anchors

DIVISION: 05 00 00—METALS

Section: 05 05 19—Post-Installed Concrete Anchors

REPORT HOLDER:

ITW RED HEAD

EVALUATION SUBJECT:**TAPCON+ SCREW ANCHORS AND SAMMYS THREADED ROD ANCHORS FOR USE IN CRACKED AND UNCRACKED CONCRETE****1.0 REPORT PURPOSE AND SCOPE****Purpose:**

The purpose of this evaluation report supplement is to indicate that Tapcon+ Screw Anchors and SAMMYS Threaded Rod Anchors for use in cracked and uncracked concrete, described in ICC-ES evaluation report [ESR-3699](#), have also been evaluated for compliance with the codes noted below as adopted by Los Angeles Department of Building and Safety (LADBS).

Applicable code editions:

- 2020 *City of Los Angeles Building Code* (LABC)
- 2020 *City of Los Angeles Residential Code* (LARC)

2.0 CONCLUSIONS

The Tapcon+ Screw Anchors and SAMMYS Threaded Rod Anchors for use in cracked and uncracked concrete, described in Sections 2.0 through 7.0 of the evaluation report [ESR-3699](#), comply with LABC Chapter 19, and LARC, and are subjected to the conditions of use described in this report.

3.0 CONDITIONS OF USE

The Tapcon+ Screw Anchors and SAMMYS Threaded Rod Anchors described in this evaluation report must comply with all of the following conditions:

- All applicable sections in the evaluation report [ESR-3699](#).
- The design, installation, conditions of use and labeling of the anchors are in accordance with the 2018 *International Building Code*® (IBC) provisions noted in the evaluation report [ESR-3699](#).
- The design, installation and inspection are in accordance with additional requirements of LABC Chapters 16, 17, and City of Los Angeles Information Bulletin P/BC 2020-092as applicable. References to Los Angeles Research Reports (LARR) within the COLA Information Bulletin P/BC may be substituted with this supplement.
- Under the LARC, an engineered design in accordance with LARC Section R301.1.3 must be submitted.
- The allowable and strength design values listed in the evaluation report and tables are for the connection of the anchors to the concrete. The connection between the anchors and the connected members shall be checked for capacity (which may govern).
- For use in wall anchorage assemblies to flexible diaphragm applications, anchors shall be designed per the requirements of City of Los Angeles Information Bulletin P/BC 2020-071.

This supplement expires concurrently with the evaluation report, reissued March 2024.

DIVISION: 03 00 00—CONCRETE
Section: 03 16 00—Concrete Anchors

DIVISION: 05 00 00—METALS
Section: 05 05 19—Post-Installed Concrete Anchors

REPORT HOLDER:

ITW RED HEAD

EVALUATION SUBJECT:

TAPCON+ SCREW ANCHORS AND SAMMYS THREADED ROD ANCHORS FOR USE IN CRACKED AND UNCRACKED CONCRETE

1.0 REPORT PURPOSE AND SCOPE

Purpose:

The purpose of this evaluation report supplement is to indicate that Tapcon+ screw anchors and SAMMYS threaded rod anchors for use in cracked and uncracked concrete, described in ICC-ES evaluation report ESR-3699, have also been evaluated for compliance with the codes noted below.

Applicable code editions:

- 2022 California Building Code (CBC)

For evaluation of applicable Chapters adopted by the California Office of Statewide Health Planning and Development (OSHPD) AKA: California Department of Health Care Access and Information (HCAI) and the Division of State Architect (DSA), see Sections 2.1.1 and 2.1.2 below.

- 2022 California Residential Code (CRC)

2.0 CONCLUSIONS

2.1 CBC:

The Tapcon+ screw anchors and SAMMYS threaded rod anchors for use in cracked and uncracked concrete, described in Sections 2.0 through 7.0 of the evaluation report ESR-3699, comply with CBC Chapter 19, provided the design and installation are in accordance with the 2021 *International Building Code*® (IBC) provisions noted in the evaluation report and the additional requirements of CBC Chapters 16 and 17.

2.1.1 OSHPD: The applicable OSHPD Sections and Chapters of the CBC are beyond the scope of this supplement.

2.1.2 DSA: The applicable DSA Sections and Chapters of the CBC are beyond the scope of this supplement.

2.2 CRC:

The Tapcon+ screw anchors and SAMMYS threaded rod anchors for use in cracked and uncracked concrete, described in Sections 2.0 through 7.0 of the evaluation report ESR-3699, comply with CRC Section R301.1.3, provided the design and installation are in accordance with the 2021 *International Building Code*® (IBC) provisions noted in the evaluation report and the additional requirements of CBC Chapters 16 and 17.

This supplement expires concurrently with the evaluation report, reissued March 2024.

DIVISION: 03 00 00—CONCRETE

Section: 03 16 00—Concrete Anchors

DIVISION: 05 00 00—METALS

Section: 05 05 19—Post-Installed Concrete Anchors

REPORT HOLDER:

ITW RED HEAD

EVALUATION SUBJECT:

TAPCON+ SCREW ANCHORS AND SAMMYS THREADED ROD ANCHORS FOR USE IN CRACKED AND UNCRACKED CONCRETE

1.0 REPORT PURPOSE AND SCOPE

Purpose:

The purpose of this evaluation report supplement is to indicate that Tapcon+ Screw Anchors and SAMMYS Anchors for Threaded Rods for use in cracked and uncracked concrete, described in ICC-ES evaluation report ESR-3699, have also been evaluated for compliance with the codes noted below.

Compliance with the following codes:

- 2020 Florida Building Code—Building
- 2020 Florida Building Code—Residential

2.0 PURPOSE OF THIS SUPPLEMENT

The Tapcon+ Screw Anchors and SAMMYS Screw Anchors for use in cracked and uncracked concrete, described in Sections 2.0 through 7.0 of the evaluation report, ESR-3699, comply with the *Florida Building Code—Building* and *Florida Building Code—Residential*, provided the design requirements are determined in accordance with the *Florida Building Code—Building* or *Florida Building Code—Residential*, as applicable. The installation requirements noted in ICC-ES evaluation report, ESR-3699 for the 2018 *International Building Code*® meet the requirements of the *Florida Building Code—Building* or *Florida Building Code—Residential*, as applicable.

Use of the Tapcon+ Screw Anchors and SAMMYS Screw Anchors for use in cracked and uncracked concrete, for compliance with the High-Velocity Hurricane Zone provisions of the *Florida Building Code—Building* and *Florida Building Code—Residential*, have not been evaluated, and is outside the scope of this supplemental report.

For products falling under Florida Rule 61G20-3, verification that the report holder's quality-assurance program is audited by a quality-assurance entity approved by the Florida Building Commission for the type of inspections being conducted is the responsibility of an approved validation entity (or the code official, when the report holder does not possess an approval by the Commission).

This supplement expires concurrently with the evaluation report, reissued March 2024.